

Multi-Bay Smart Charging System Instructions for use

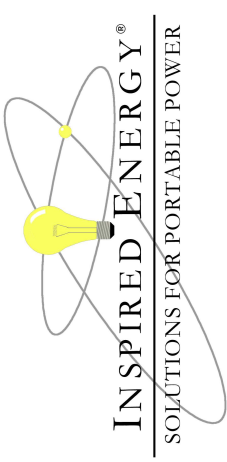

Multi-Bay Charge System Specification Summary (4-Bay & 6-Bay versions)	
Weight:	4-Bay: 3.1kg / 6.9lb, 6-Bay: 3.3kg / 7.2lb
Height:	127mm / 5"
Length:	400mm / 16"
Width:	203mm / 8"
Mating Connectors:	5-blade standard battery connector
Communications Compliances:	System Management Bus Rev 1.0, Smart Battery Data Specification rev 1.0 and Smart Battery Charger specification Rev 1.0 compliant
Charger Units	24V DC, FCC & CE Compliant, RoHS Compliant
Power Supply	110-250VAC, 50-60Hz, UL listed, FCC & CE Compliant, RoHS Compliant
Mains Cord	"A" part number suffix - 110V N. American 3-pin connector "E" part number suffix - 220V European 2-pin connector with ground recess "U" part number suffix - 240V UK 3-pin connector



CH5555
4-Bay Unit



CH6555
6-Bay Unit

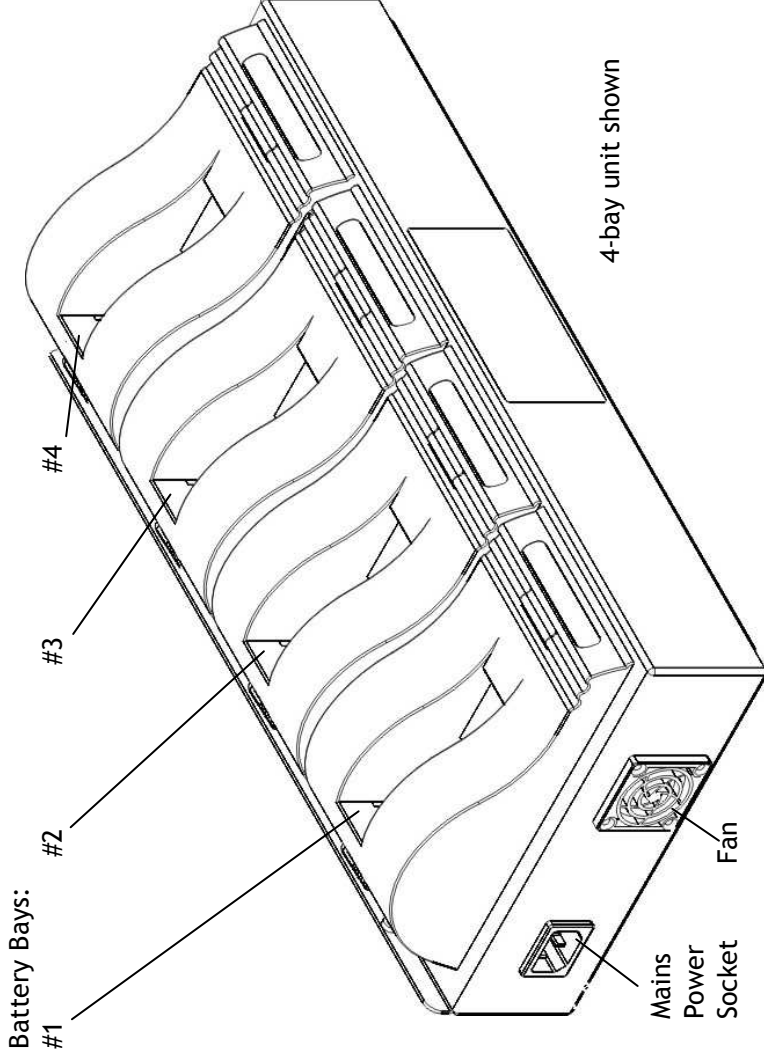

The Inspired Energy Multi-Bay smart charging systems work with all Inspired Energy® brand smart standard packs and hybrids irrespective of size, shape, voltage, cell chemistry or capacity.

Component parts

- One multi-bay smart charging unit:
 - CH5555 = Four smart charger / calibrator bays
 - CH5544 = Two smart charger/calibrator bays + two smart charger bays
 - CH4444 = Four smart charger bays
 - CH6555 = Six smart charger / calibrator bays
 - CH6444 = Six smart charger bays
- Three plastic spacers per bay to modify the battery bays to suit your battery sizes
- One mains cable:
 - North American units ("A" part number suffix) are packed with a US 3-pin mains cord
 - European units ("E" part number suffix) are packed with a European 2-pin mains cord
 - UK units ("U" part number suffix) are packed with a UK 3-pin mains cord

Safety

- Do not expose the charger or power supply to water or liquids.
- Do not open the charger or power supply case, no user serviceable parts are inside.
- Do not cover the fan exhaust or obstruct the airflow, this will cause overheating.
- Place the charger in a cool spot, away from external heat sources
- Caution - during recalibration the charger may become warm.

Inspired Energy, LLC. 25440 NW 8th Place, Newberry, FL 32669

US toll free: 1-888-5-INSPIRE (1-888-546-7747) Tel: 352 472 4855 Fax: 352 472 4859

www.inspiredenergy.com

Multi-Bay Charger Instructions 09-04-24.doc

Part #: 908006

Using your Charger

Place the charger on a flat, level surface away from sources of heat and moisture. Connect the power supply to the mains AC supply using the cable supplied. (The LEDs will flash on powering up the unit.) Place the battery into the battery bay ensuring that the 5-way connector is fully seated. The LEDs in the status window will provide status information and the charger will automatically begin charging. Each charge bay operates independently providing simultaneous charge for up to four or six battery packs. A typical charge + calibration bay is shown below. Bays without calibration function have the calibration button disabled.

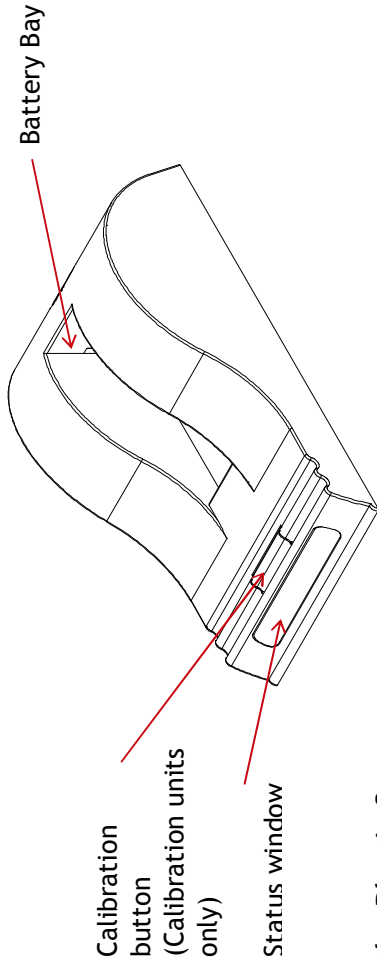

Using the Plastic Spacers

Plastic spacers are supplied to assist in the correct insertion of all of the different sizes of smart standard packs. To insert a spacer, place the bottom of the spacer in the rear corner of the battery bay. Place a thumb on the top of the spacer and push it firmly towards the back of the charger. Correct insertion should be accompanied by a click as the guides lock into place. The cross reference of spacers to batteries is given below:

Thick "L" shaped spacer: NI1030, NC2560 & ND2017 Style
 Thin "L" shaped spacer: NJ1020 & NI2020 Style
 Flat spacer: NL2020 & NL2024
 No spacer is required for the 204x or 205x ranges of batteries.

LED Indication:

The status of the battery is indicated by the LEDs visible in the status window:
 Charge Bay indications:

- * Green flashing: Battery charging
- Green solid: Battery fully charged
- Red solid: Error
- * Green flashing: Battery charging
- Green solid: Battery fully charged
- * Blue flashing: Battery in calibration mode
- Blue solid: Battery fuel gauge calibrated
- * Red flashing: Battery fuel gauge in need of recalibration
- Red solid: Error

Recharge Time:

Different battery packs require differing recharge times. The times given below are for a full charge from 0% state of charge. They are valid for all variants and custom hybrids of each battery model.

Battery Chemistry	Battery Model	Recharge Time (hours)	Recalibration Time (hours)
NiMH	NI1030, NJ1020	1.5	5 - 7
	NC2040, NC2560, ND2054	2.5	5 - 7
Li Ion	ND2053	3.5	30 - 35
	ND2057	2	9 - 11
	NF2040, NF2047	3	7 - 11
	NH2057, NH2054	5	18 - 24
	ND2017, NI2020, NI2040	3.5	10 - 13
	NL2020, NL2050	4	12 - 15
	NL2024, NL2044, NL2054	3	7 - 10

Battery Fuel Gauge Recalibration (Units with calibration features only)

If the battery is in need of fuel gauge recalibration, the red LED on the charge bay will flash. The user has the option to calibrate the fuel gauge and charge the battery, or to only charge the battery. To recalibrate the fuel gauge, press the calibrate button in front of the battery bay. Calibration is initiated each time the button is pressed, so it is not recommended to press the recalibration button part way through the recalibration cycle. The blue calibration LED will flash to indicate that the battery is undergoing the recalibration cycle. When calibration is complete the blue LED will stay constant.

What is Recalibration?

Recalibration is used to re-turn the battery fuel gauge to full accuracy. In this way, as the battery ages, the accuracy and reliability of the fuel gauge can be retained throughout the life of the battery.

How does the charger know what charge to deliver?

Each charger unit is capable of sensing and delivering an appropriate charge to all Inspired Energy NiMH and Li ion standard battery packs. Upon inserting the battery into the charger, the battery communicates to the charger over the SMBus data link, telling the charger what type of cell chemistry it is and what charge regime it needs. The charger then configures its output to provide the charge regime requested by the battery. If no SMBus communications are issued from the battery, the charger interrogates the thermistor/resistor I.D. pin on the battery terminal and delivers an appropriate charge.

Compatibility

The system is fully compatible with all Inspired Energy® brand standard battery packs and their custom hybrids. For optimum results and safety, we recommend using only Inspired Energy® brand smart batteries. For a full list of all compatible Inspired Energy batteries, please visit:

www.inspiredenergy.com